



Datu lapa

2026-06-28

# Kos V

Laikmetīga, minimālistiska elegances.

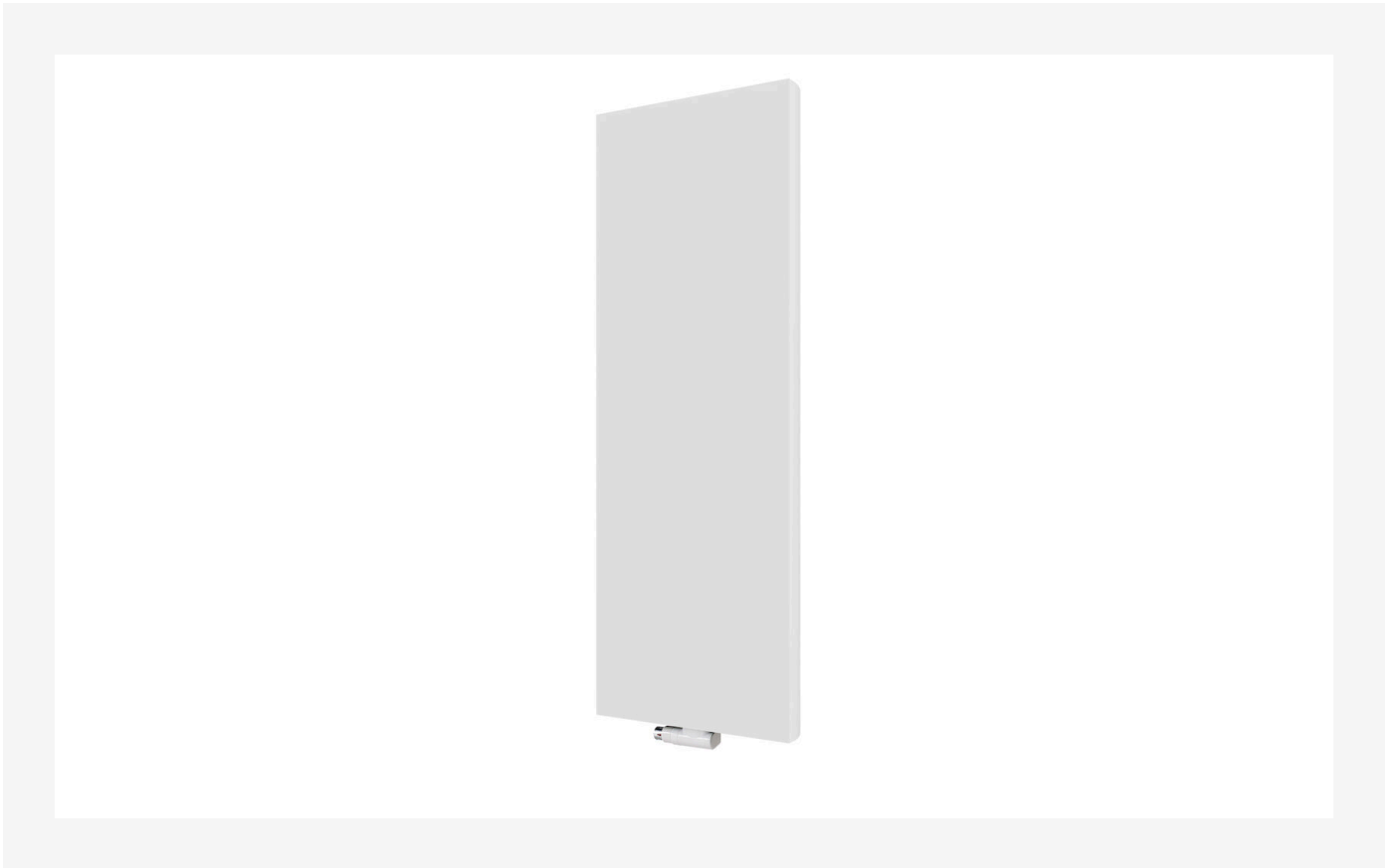

- ✓ Elegants, laikmetīgs dizains
- ✓ Piemērots ierobežotai sienas vietai
- ✓ Augstas kvalitātes nerūsējošā tērauda dvieļu turētājs
- ✓ Pieejams vairākās krāsās
- ✓ Piemērots interjeram

**Kos V** vertikālais radiators ar perfektu plakanu priekšējo plātņi un mīkstām malām piedāvā tīru, modernu estētiku un ir ideāls šaurām sienām; pieejams RAL krāsās un nerūsējošā tērauda versijā.



### **Pielietojuma joma**

Vertikāls radiators mājokļiem un komercijai, īpaši šaurās vietās. Plakana tērauda plate, sānu paneļi, augšējā reste. Piemērots 2-cauruļu sistēmām.

### **Dimensiju noteikšana**

Lai nodrošinātu pareizu produktu izvēli, lūdzu, izmantojiet mūsu kalkulatoru rīkus un produktu bukletus. Ja nepieciešama palīdzība, sazinieties ar mūsu pārdošanas komandu.

### **Lietošana**

Uzstādi radiatoru ar piegādātajiem regulējamajiem sienas kronšteinjiem, pārliedzinoties, ka pieslēgumi atbilst

četriem 1/2 collu vītņotajiem ieplūdes portiem; pēc uzstādīšanas piepildi sistēmu ar ūdeni un atgaiso to ar 1/4 collu atgaisošanas vārstu un regulāri pārbaudi savienojumus, tīrot virsmu ar mīkstu neabrazīvu drānu.

### **AMA teksts**

Kos V vertikālais radiators ar gludu priekšējo paneli un noapaļotām malām nodrošina vienkāršu, modernu formu, kas piemērota šaurām sienas zonām. Pieejams dažādos RAL toņos un nerūsējošā tērauda versijā. Piemērots virtuvēm un vannas telpām; pieejams nerūsējošā tērauda dvieļu turētājs. Komplektā iekļauti stiprinājumi, montāžas komplekts, aizbāžņi un atgaisošanas vārsts. Standarta krāsa RAL 9016.



# Specifikācijas

ĪPAŠĪBAS	VIENĪBA	VĒRTĪBAS
ETIM klase		EC011022
Materiāls		Tērauds
Tips		20, 21, 22
Virsmas struktūra		Līdzens gluds
Maks. darba spiediens	bar	10
Standarta pieslēgumu skaits		4
Siltuma atdeve pēc EN 442 atzītas laboratorijas		Jā
Maksimālā darbības temperatūra	°C	110
Standarta krāsa		Jā
Krāsa		Balts
RAL numurs		9016
Restes/Vāka plāksne		Jā
Restes/Vāka plāksne		Jā
Spīduma vērtība		Spīdīgs
Vītnes izmērs (collas)		1/2 inch
Pieslēguma vītne		Iekšējā vītne
Ar vienpunkta pieslēgumu		Jā
Ar ventilācijas pieslēgumu		Jā
Ar ventilācijas vārstu/gaisa atgaisotāju		Jā
Ar iztukšošanas iespēju		Jā





# Resursi

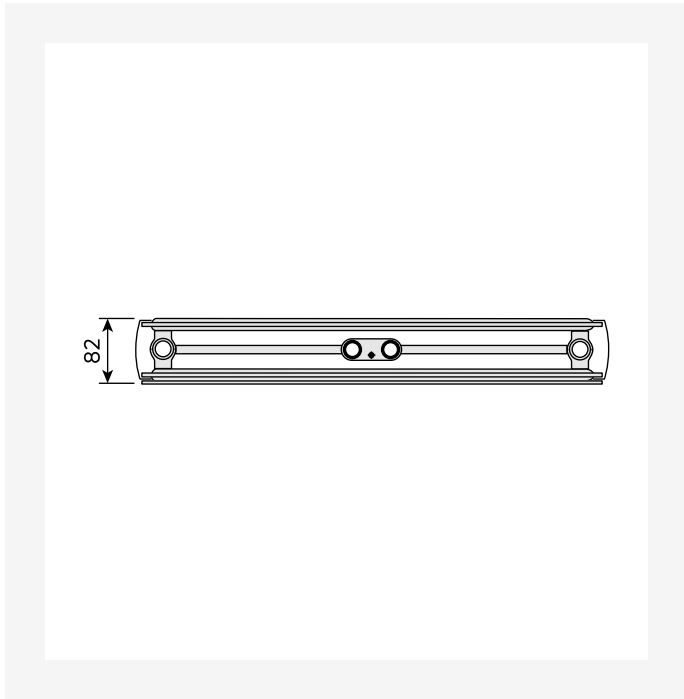
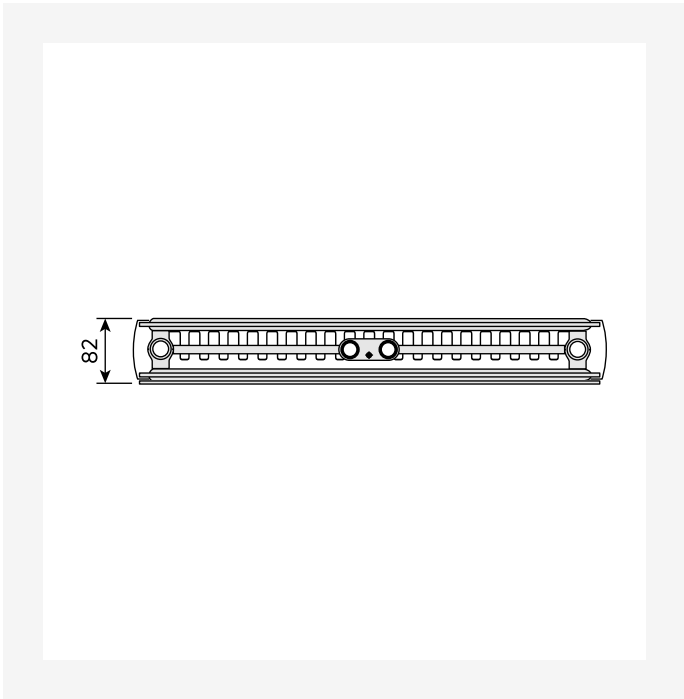

DimensionalDrawing - Kos V / Faro V, tips 21, skats no augšas

DimensionalDrawing - Kos V / Faro V, tips 20, skats no augšas

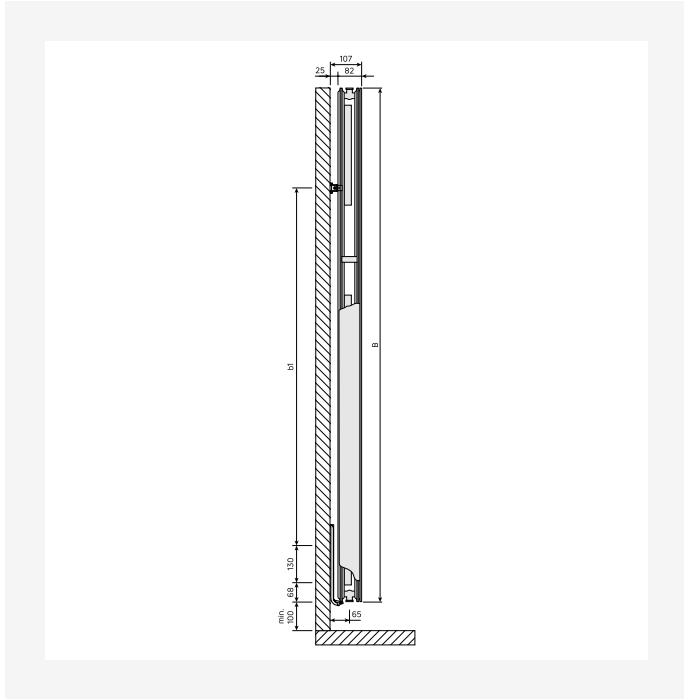
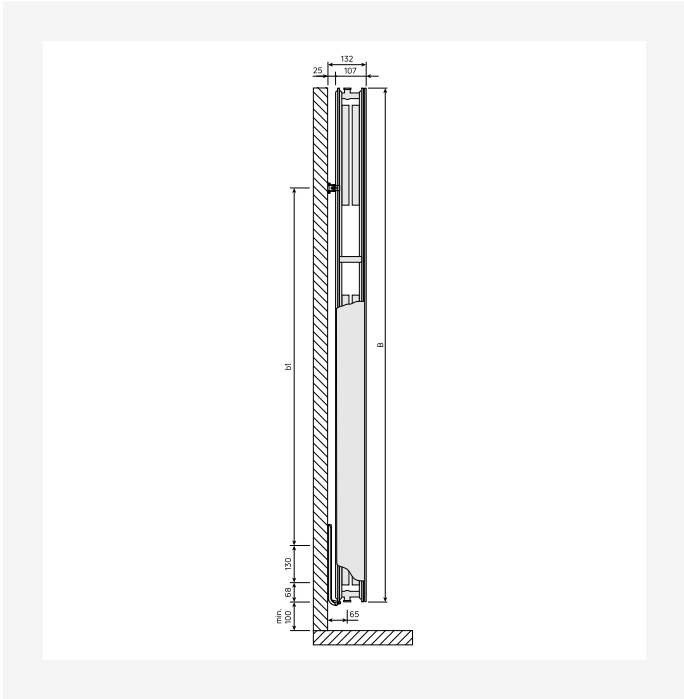

DimensionalDrawing - Kos V / Faro V, tips 22, skats no sāniem

DimensionalDrawing - Kos V / Faro V, tips 21, skats no sāniem



# Resursi

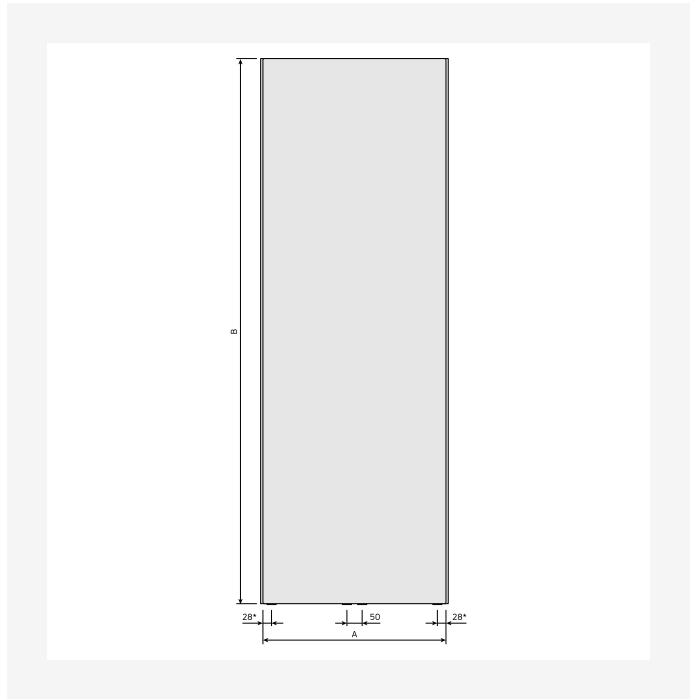
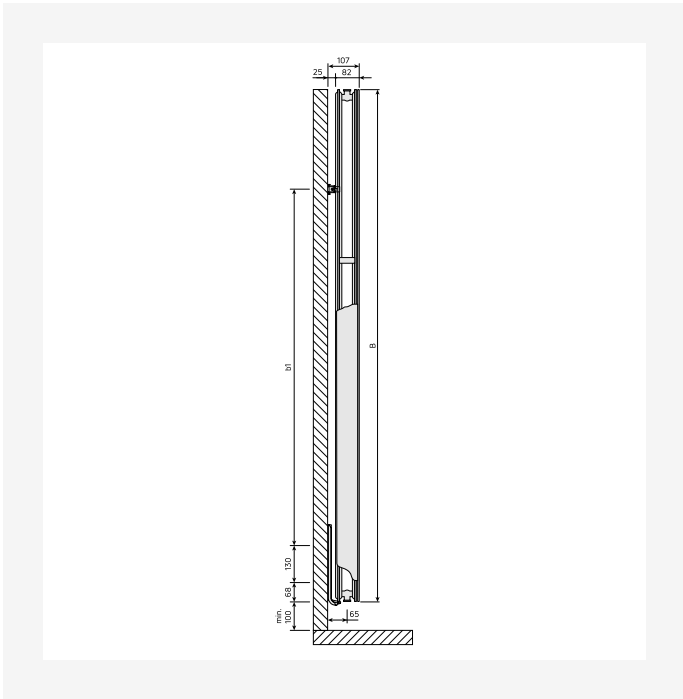

DimensionalDrawing - Kos V / Faro V, tips 20, skats no sāniem

DimensionalDrawing - Kos V, skats no priekšpuses

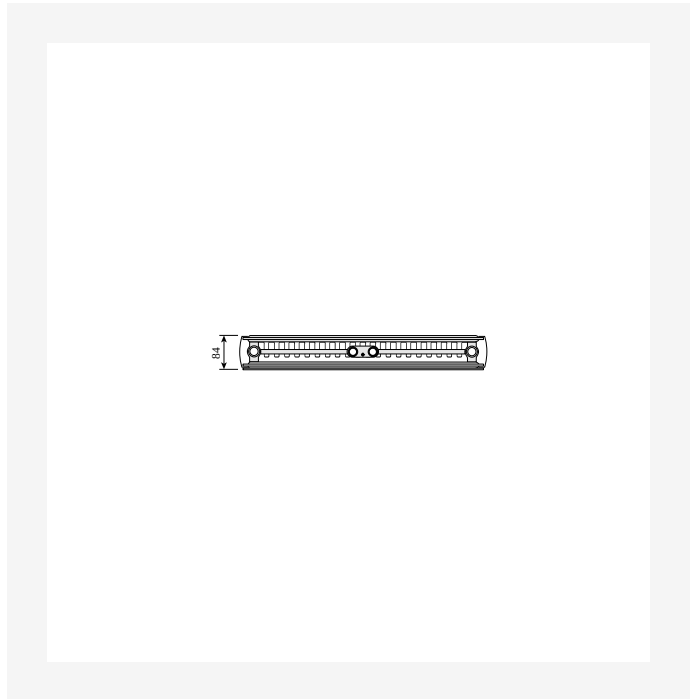
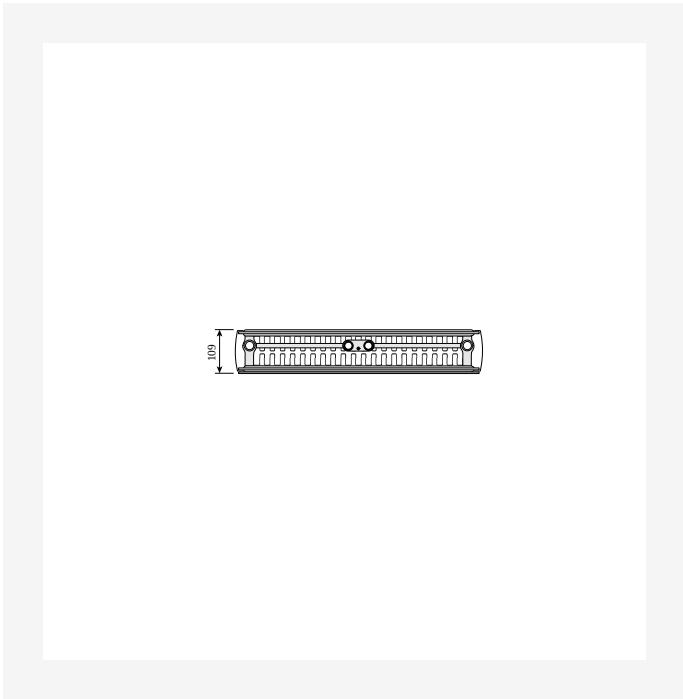

DimensionalDrawing - Kos V un Faro V, tips 22, skats no augšas

DimensionalDrawing - Kos V un Faro V, tips 21, skats no augšas





# Resursi

KOS V (mm)				
A	320	470	620	770
a1	60	135	210	285
a2	75	125	200	250

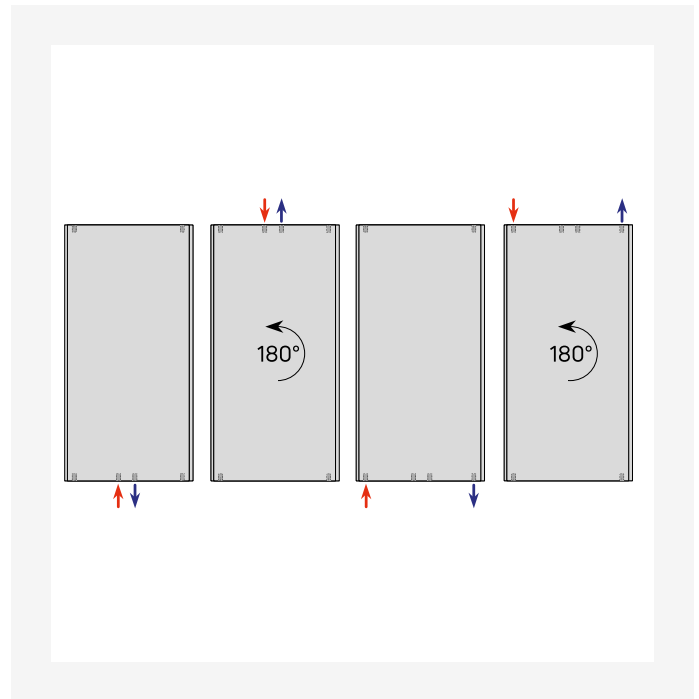

DimensionalDrawing - Kos V, Faro V, tabula A

DimensionalDrawing - Vertikālās pieslēguma iespējas

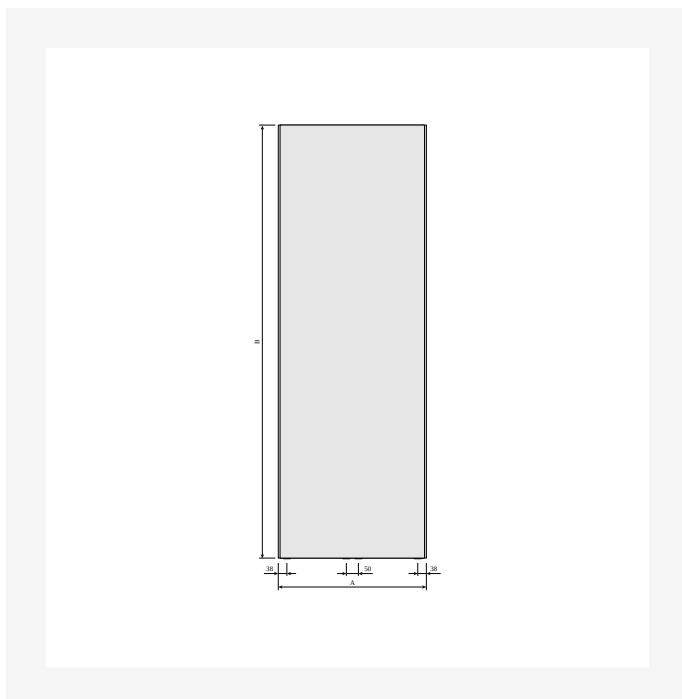

DimensionalDrawing - Kos V, skats no priekšpuses

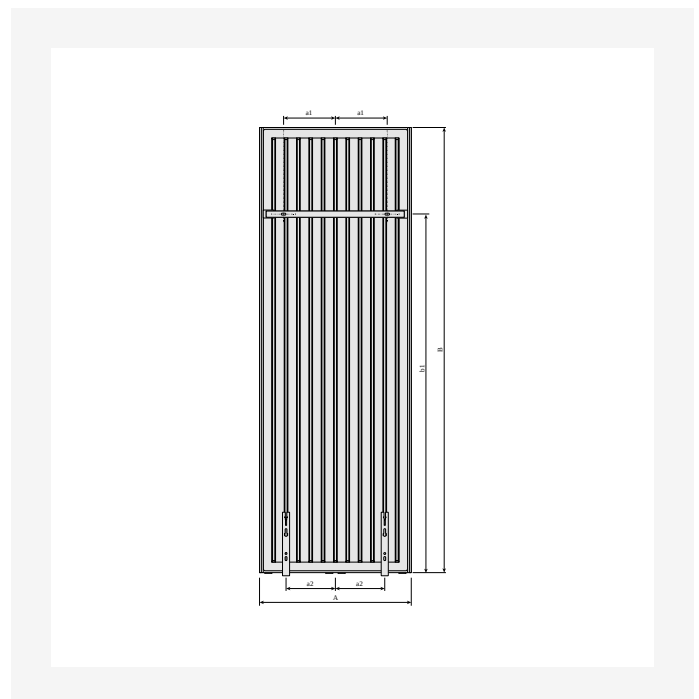

DimensionalDrawing - Kos V un Faro V ar MCWV sienas kronšteiniem, skats no aizmugures



# Resursi

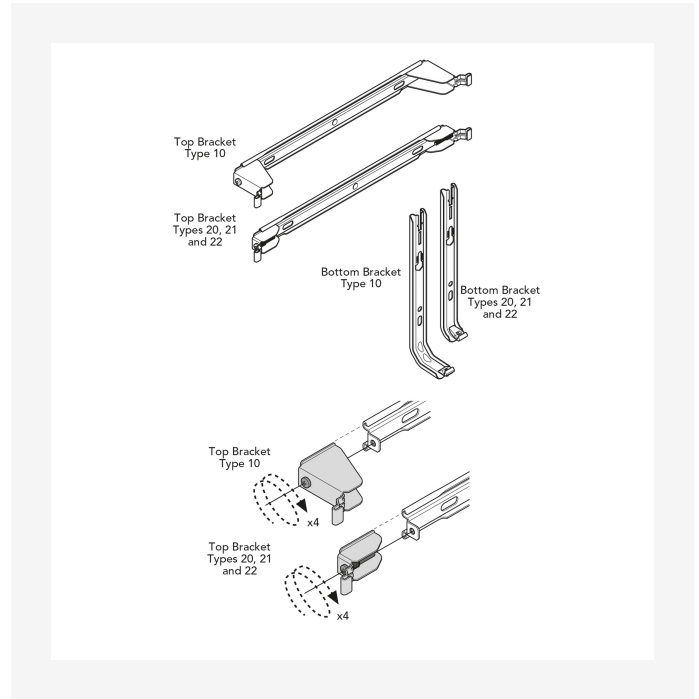
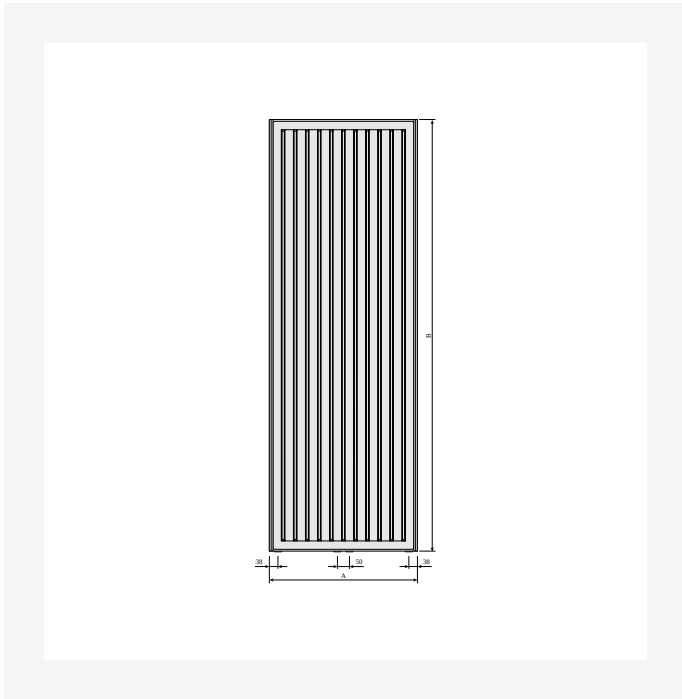

Dimensional Drawing - Kos V un Faro V, skats no aizmugures

Dimensional Drawing - Purmo Vertical, Plan & Plan Plus Vertical kronšteini

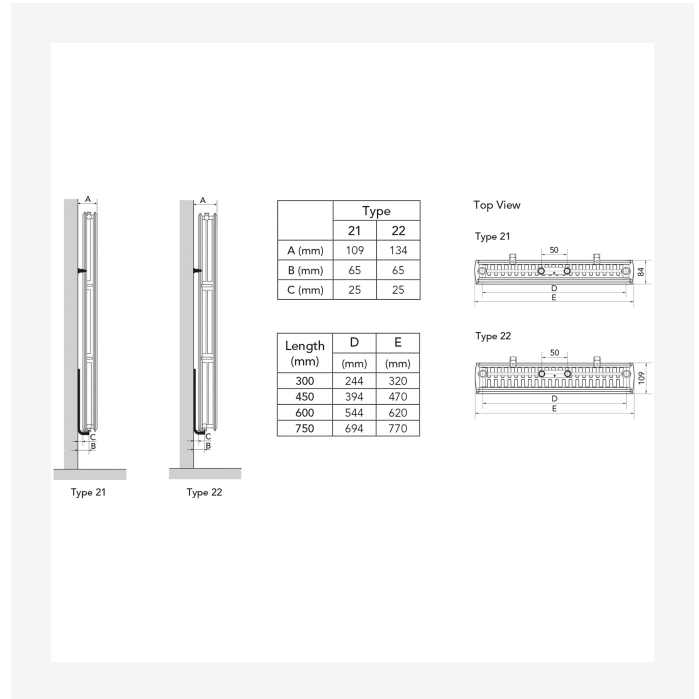
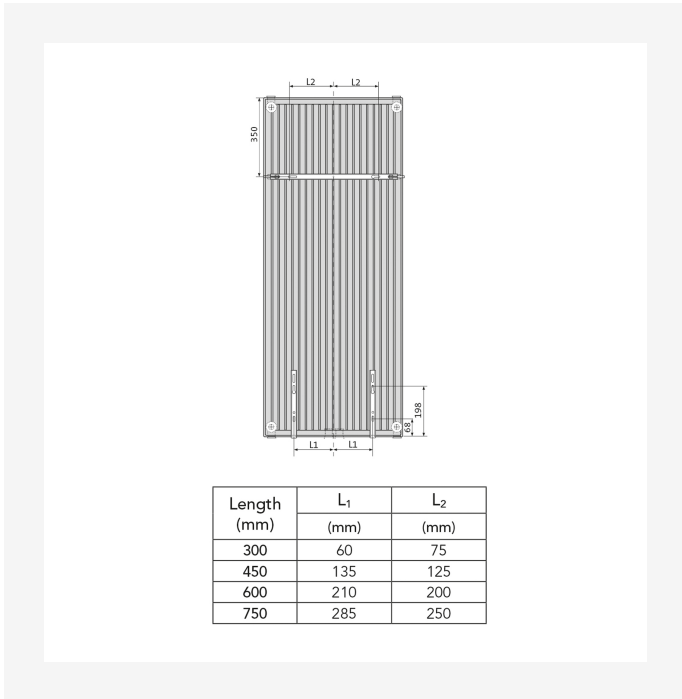

Dimensional Drawing - Purmo Vertical Plan & Plan Plus Vertical – kronšteinu pozīcijas un izmēri

Dimensional Drawing - Purmo Plan & Plan Plus Vertical – montāžas pozīcijas un izmēri



# Resursi

KOS V (mm)			
<b>B</b>	1800	1950	2100
<b>b1</b>	1450	1600	1750
<b>b2</b>	1252	1402	1552

KOS V (mm)				
<b>B</b>	1500	1800	1950	2100
<b>b1</b>	1150	1450	1600	1750
<b>b2</b>	952	1252	1402	1552

DimensionalDrawing - Kos V, Faro V – tabula B – PL

DimensionalDrawing - Kos V, Faro V – tabula B



# Saistītie produkti



Plan Compact (FC)



Dvieļu statīvs Vertical



Dvieļu statīvs Kos V / Faro V



Gaisa ventilēšanas atslēga



Sānu panelis Kos V/Faro V



Remonta krāsas sprejs



# 1500

AUGSTUMS 1500 mm	GARUMS	DZIĻUMS		Jauda (W) 45/35/20°C	Jauda (W) 55/45/20°C	Jauda (W) 60/45/20°C	TILPUMS (l)	N- ekponents	SVARS (kg)
<b>Tips 21</b>									
	300	82	FMX2115003011300	252	436	--	4.0	1.30	27.3
	450	82	FMX2115004511300	366	634	--	6.1	1.30	39.2
	600	82	FMX2115006011300	476	826	--	8.2	1.30	51.1
	750	82	FMX2115007511300	--	1014	--	10.3	1.30	63.0
<b>Tips 22</b>									
	300	107	FMX2215003011300	300	521	--	4.0	1.31	29.8
	450	107	FMX2215004511300	442	769	--	6.2	1.31	43.1
	600	107	FMX2215006011300	581	1014	--	8.3	1.31	56.5
	750	107	FMX2215007511300	--	1255	--	10.3	1.32	69.8



# 1800

AUGSTUMS 1800 mm	GARUMS	DZIĻUMS		Jauda (W) 45/35/20°C	Jauda (W) 55/45/20°C	Jauda (W) 60/45/20°C	TILPUMS (l)	N- ekponents	SVARS (kg)
<b>Tips 20</b>									
	300	82	FMX2018003011300	429	459	--	4.8	1.28	30.1
	450	82	FMX2018004511300	382	657	--	7.2	1.28	42.9
	600	82	FMX2018006011300	491	847	--	9.7	1.29	55.6
	750	82	FMX2018007511300	--	1031	--	12.1	1.29	0.0
<b>Tips 21</b>									
	300	82	FMX2118003011300	286	495	536	4.8	1.29	31.7
	450	82	FMX2118004511300	414	716	776	7.2	1.30	45.8
	600	82	FMX2118006011300	535	930	1008	9.7	1.31	59.9
	750	82	FMX2118007511300	653	1139	1235	12.1	1.31	74.0
<b>Tips 22</b>									
	300	107	FMX2218003011300	342	592	--	4.8	1.30	35.1
	450	107	FMX2218004511300	503	873	--	7.3	1.30	50.6
	600	107	FMX2218006011300	660	1149	--	9.7	1.31	66.1
	750	107	FMX2218007511300	815	1421	--	12.2	1.31	79.8



# 1950

AUGSTUMS 1950 mm	GARUMS	DZIĻUMS		Jauda (W) 45/35/20°C	Jauda (W) 55/45/20°C	Jauda (W) 60/45/20°C	TILPUMS (l)	N- ekponents	SVARS (kg)
<b>Tips 20</b>									
	300	82	FMX2019503011300	463	495	--	5.2	1.28	32.5
	450	82	FMX2019504511300	412	709	--	7.8	1.28	45.9
	600	82	FMX2019506011300	836	914	--	10.4	1.29	59.3
	750	82	FMX2019507511300	645	1113	--	13.0	1.29	72.8
<b>Tips 21</b>									
	300	82	FMX2119503011300	302	521	565	5.2	1.29	34.1
	450	82	FMX2119504511300	437	756	820	7.8	1.30	49.3
	600	82	FMX2119506011300	568	985	1067	10.4	1.30	64.4
	750	82	FMX2119507511300	694	1207	1308	13.0	1.31	79.6
<b>Tips 22</b>									
	300	107	FMX2219503011300	361	624	--	5.3	1.29	37.3
	450	107	FMX2219504511300	532	922	--	7.8	1.30	53.8
	600	107	FMX2219506011300	698	1213	--	10.4	1.30	70.3
	750	107	FMX2219507511300	861	1500	--	13.1	1.31	85.9



# 2100

AUGSTUMS 2100 mm	GARUMS	DZIĻUMS		Jauda (W) 45/35/20°C	Jauda (W) 55/45/20°C	Jauda (W) 60/45/20°C	TILPUMS (l)	N- ekponents	SVARS (kg)
<b>Tips 20</b>									
	300	82	FMX2021003011300	311	532	--	5.6	1.27	34.8
	450	82	FMX2021004511300	443	761	--	8.4	1.27	49.8
	600	82	FMX2021006011300	902	980	--	11.1	1.28	64.8
	750	82	FMX2021007511300	690	1191	--	13.9	1.29	79.8
<b>Tips 21</b>									
	300	82	FMX2121003011300	315	548	593	5.6	1.29	36.5
	450	82	FMX2121004511300	460	796	862	8.4	1.29	52.7
	600	82	FMX2121006011300	600	1038	1125	11.1	1.30	69.0
	750	82	FMX2121007511300	737	1276	1382	13.9	1.30	85.2
<b>Tips 22</b>									
	300	107	FMX2221003011300	380	655	--	5.7	1.29	40.4
	450	107	FMX2221004511300	559	967	--	8.4	1.29	58.0
	600	107	FMX2221006011300	734	1273	--	11.2	1.30	75.6
	750	107	FMX2221007511300	1372	1574	--	13.9	1.30	92.3